

espresso, café crème, caffè latte,  
cappuccino, latte macchiato,  
mocha, caffè macchiato, ristretto

# Eta Beta V2



**Eta Beta COF:**

high-raised groups and fold-down trays;  
all selections dedicated to coffee

**Eta Beta LM:**

high-raised groups and fold-down trays;  
automatic milk frother for espresso-milk-based drinks

**Eta Beta COF:**

hoher Auslauf und klappbarer Tassentisch;  
alle Auswahlkosten zur Ausgabe von Kaffeeprodukten

**Eta Beta LM:**

hoher Auslauf und klappbarer Tassentisch;  
automatischer Milchaufschäumer für Spezialitäten  
auf Espresso-Milch-Basis



1 group



3 groups

Finishing: super mirror stainless steel or blue panels





## Technical Specifications

### Characteristics

Traditional coffee machine with automatic dosage and high-capacity boilers

- 7 tac-switch back-lighted selection buttons, programmable as desired for any coffee and milk-based drinks
- LM version: automatic milk frother with self-cleaning system after each delivery
- Two automatic dosages of hot water
- Two steam levers
- Built-in motor pump
- Groups attached to thermostatically controlled boiler: adjustable brewing temperature for consistently superior flavour shot after shot
- Temperature probe for constant control of steam boiler pressure
- Boiler and pump pressure gauge
- No-return system of liquids into the boiler and in the steam taps by means of vacuum valves
- Thermostat safety sensor for boiler heating element

### Software & Display

- Counting of dispensed drinks
- Counting of extraction time
- Programming of pre-infusion for all key buttons of each group
- Access to programming by means of password
- Boiler temperature and clock displayable
- Programming of machine maintenance after programmable number of coffee doses
- Programming of litres for water softener renewal
- Programming of switching on and off of the machine and of one rest-day
- PC board having 32 KB rewritable flash memory
- Slave PC board to operate milk frothers

### Optional

- Barista steam wand
- Water softeners (8 or 12 litre)
- Manual milk frother
- Adjustable filter holder for coffee pods
- RS232 serial connection for Interface I/O 26 relé and cash register

## Technische Daten

### Daten

*Espressomaschinen mit automatischer Dosierung und großem Kesselvolumen*

- 7 beleuchtete Produkttasten, frei programmierbar für alle Kaffee- und Milchprodukte
- LM-Version: automatischer Cappuccinatore mit Selbstreinigungssystem nach jeder Ausgabe
- eingebaute Pumpe
- Die Brühgruppen sind mit dem thermostatgesteuerten Kessel verbunden: einstellbare Brühtemperatur, um Tasse für Tasse höchsten Qualitätsansprüchen zu genügen
- Temperatur-Messfühler zur konstanten Steuerung des Dampfkesseldrucks
- Kessel- und Pumpendruck-Anzeige
- Belüftungsventile, die ein Zurückfließen von Flüssigkeiten in den Kessel und in das Dampfsystem verhindern
- Sicherheitsthermostat für die Kesselheizung
- zwei Heißwasser-Dosiermengen
- zwei Dampfhebel

### Software & Display

- Getränke-zähler
- Auslaufzeit-Zähler
- Programmierung der Pre-Infusion für alle Produkttasten
- Zugang zur Programmierung über Passworteingabe
- Kesseltemperatur- und Zeitanzeigemöglichkeit
- Programmierung der gewünschten Wartungszyklen
- Programmierung der Austauschintervalle für den Wasserfilter (in Litern)
- Programmierung von automatischen Ein- und Ausschaltzeiten und Ruhetagen
- Platine mit 32 KB Flash-Memory
- Zusatzplatine für den Betrieb des Cappuccinatore

### Optional

- Barista Dampfahh mit Temperaturfühler
- Wasserenthärtungsanlage (8 oder 12 Liter)
- manueller Cappuccinatore
- Umbau-Kit für den Betrieb mit Kaffee-Pouches
- serielle RS232-Schnittstelle für den Anschluss an einen PC und/oder eine Registrierkasse

### Drink Selections / Getränke-Optionen



espresso



cappuccino



latte macchiato



café crème



hot milk



frothy milk



hot water



## Barista steam wand

Steam wand allowing to steam and froth milk AUTOMATICALLY, with temperature probe that cuts off automatically once the set temperature is reached or that can be manually stopped.

## Barista Steam Dampfahh mit Temperaturfühler

Dieser Dampfauslauf dient zum AUTOMATISCHEN Schäumen und Erhitzen der Milch. Der Dampfauslauf wird vom Anwender manuell eingeschaltet, stoppt aber, sobald die eingestellte Temperatur erreicht ist.

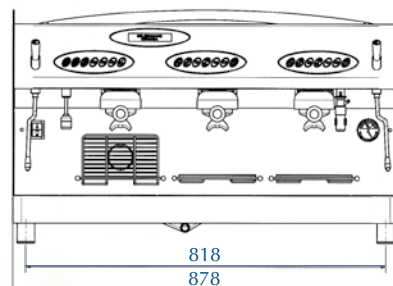
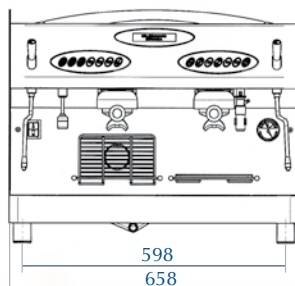
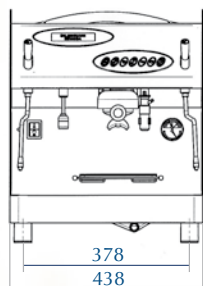
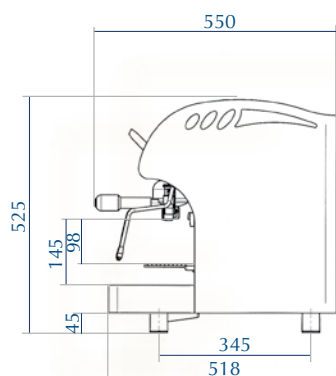

## Technical features / Technische Merkmale



1 group	2.800W+300W 230V 1N~ 1.600W+350W 120V 1N~	8,0 l	44 Kg	60 Kg
2 group	3.500W+350W 230V 1N~ 400V 3N~ 4.500W+350W 230V 1N~ 400V 3N~	13,5 l	59 Kg	73 Kg
3 group	4.500W+350W 230V 1N~ 400V 3N~	20,0 l	71 Kg	90 Kg



Milk Frother Cleaner  
- Breaks down milk buildup  
- Cleans steam wands and pitchers



Cleaning Tablets  
- Cleaning detergent tablets  
- 120 tablets per jar

## Approvals / Zulassungen



New Eta Beta 1 USA COF/LM  
New Eta Beta 2 USA COF/LM  
New Eta Beta 3 USA COF/LM



The Manufacturer reserves the right to modify the equipment presented in this publication without notice.